

ENGINEERING DRAWING PACKET

MODEL PRO-4-1000-EP

DESIGN PRESSURE at 120°F	1000 PSI	OPERATING pH RANGE	3-11
MINIMUM OPERATING TEMP.*	20°F	CLEANING pH RANGE (less than 30 minutes)	2-12
MAXIMUM OPERATING TEMP.	120°F	APPLICATION	TYP. SEAWATER
FACTORY TEST PRESSURE	1100 PSI		
BURST PRESSURE	6000 PSI		

INTENDED USE

The **PROTEC Model PRO-4-1000-EP Pressure Vessel** is designed for continuous use as housing for membrane filtration elements to purify typical seawater at any positive pressure up to 1000 PSI. The **PRO-4-1000-EP** will accommodate most makes of four-inch nominal diameter spiral-wound elements. The element interface hardware for the specified element is supplied with the vessel.

The Model **PRO-4-1000-EP** has been designed to meet the standards of the American Society of Mechanical Engineers (ASME), Boiler and Pressure Vessel Code, Section X. At an additional cost, vessels can be inspected during fabrication by an ASME Authorized Inspector and Code stamped.

The Model **PRO-4-1000-EP** must be installed, operated and maintained using good industrial practice and following the precautions listed in order to help assure safe operation and a long service life. Misuse, improper installation or operation may result in severe bodily harm or property damage and will void the vessel warranty. Therefore, review and follow the safeguards listed below **before** placing the vessels into service.

The filament-wound reinforced plastic shell of this vessel must be allowed to expand under pressure. Any undue restraint at the support points or piping connections can cause non-repairable leaks to develop in the shell. This vessel must not be subjected to excessive stress caused by bending moments acting at the side ports in the fiberglass shell.

The end closures of the vessel must be kept dry and free of corrosion at all times. Failure to do so may result in deterioration that can lead to catastrophic failure of the vessel heads.

When requested, Bekaert Progressive Composites will assist the purchaser in determining the suitability of this standard vessel design for their operating environment. However, the final determination including the evaluation of the materials of construction for use in the specific corrosive environment shall be the responsibility of the purchaser. Alternate materials of construction may be available on special order.

Before using this engineering packet for system design or vessel installation, please verify that it is the latest revision by consulting the factory. Specifications are subject to change without notice.

PRECAUTIONS

Follow all instructions.

Failure to take every precaution listed will void the vessel warranty and may result in vessel failure.

Mount shell using furnished hardware.

Following the recommended span(s) mount the vessel until the straps are "just snug". (less than one foot lb.)

Maximize the connection flexibility.

Position the vessel and the piping so that the vessel can grow in length and diameter under pressure without any undue restraint. Δ DIA = 0.005 in. (0.1mm) and Δ L = 0.19 in. (5mm) for a length code -6 vessel.

Provide overpressure protection.

Set the safety device at not more than 105% design pressure.

Inspect end closures regularly.

Replace damaged or deteriorated components and correct the cause of any corrosion.

Relieve system pressure before working on the vessel.

Working on vessels that are under pressure may result in bodily harm and/or property damage.

Never support other components with the vessel.

Hanging piping manifolds or supporting other components with the vessel may result in vessel damage.

Never support other components with the vessel.

Hanging piping manifolds or supporting other components with the vessel may result in vessel damage.

Do not over tighten the Permeate Port connection.

Tightening the connection more than one turn past hand tight will damage the port.

Double check end closure installation

Ensure that retaining ring is in place and fully seated.

Never operate the vessel in excess of its ratings.

This practice will void the vessel warranty, shorten vessel life and could lead to bodily harm or property damage.

Do not operate the vessel permeate port over 125 psi.

Permeate pressure in excess of 125 psi must be approved by the factory prior to operation.

Operate the vessel in only positive pressure applications.

This vessel is not designed for vacuum conditions.

Flush the vessel before system shut down.

Some feed waters may cause corrosion under static conditions. Flushing with non-corrosive permeate is recommended.

Operate the vessel within the recommended pH range.

The vessel is designed for continuous use at a pH of 3-11 and for intermittent cleaning (less than 30 min. at a pH of 2-12).

*Please inform the factory when continuous operating temperature is less than 45°F.

HEAD LOADING PROCEDURE

Step 1 Inspect The Shell

Before installing the head, check the inside surface of the shell for any imperfections or foreign matter. Remove all foreign matter using a mild soap solution and rinse with clean water. To remove imperfections, lightly sand the surface of the vessel with 600-grit sandpaper and soapy water and then rinse with water can.

Step 2 Head Seal And Shell Lubrication

Ensure that the head seal is covered with a thin layer of glycerin and is free from any dirt or dust contamination. Then lubricate the inside of the shell starting directly inboard of the retaining ring groove and up the energizing ramp into the vessel bore. Only a thin layer is required. Silicone lubricants can also be used; however, care should be taken to use as little as possible. Check with your membrane supplier before using these lubricants as they can foul membranes.

Step 3 Install Head

Holding the head square to the axis of the shell, slowly push the head into the shell until the seal passes the retaining ring groove. As a resistance is felt, two hands may be required. Push the head into shell until the head clears the retaining ring groove.

Step 4 Install Retaining Ring

Remove any moisture from the retaining groove before proceeding. Carefully place the end of the retaining ring into the groove on the shell. After the ring is started, slowly push the ring towards the groove. As the ring enters the groove, continue pushing as your hand slowly rotates counter-clockwise around the inside diameter of the shell. Be careful to prevent the ring from snapping against your finger as it enters the groove.

Step 5 Reconnect Piping

Reconnect the feed and permeate manifolding to the vessel.

Step 6 Pressurize System

Before starting the system, double check that each head has been correctly installed and that all piping connections are in place. After ensuring that all required precautions have been taken, start the system.

Step 7 Check For Leaks

After system start up, verify that all connections are leak free. Fix any leaks at this time to prevent corrosion that may lead to component deterioration and possibly unsafe operation.

HEAD REMOVAL PROCEDURE

Step 1 Shut Down System

Shut down system and take all steps necessary to relieve system pressure from the vessel.

Step 2 Disconnect Piping

Carefully disconnect the feed and permeate piping from the vessel.

Mark the feed port location by marking the shell for easier installation. Set this piping in a secure place for re-assembly.

Step 3 Check End Closure

Examine the end closure for any corrosion or damage. Remove any corrosion with a wire brush and flush away the deposits with clean water. Order replacement components as required.

Step 4 Remove Retaining Ring

Pull the retaining ring out of the groove in the shell. After the ring is removed from the groove for ¼ turn, stop pulling. Finish removing the ring by running your finger behind the ring and carefully pulling the ring from groove. It is best to follow the ring in a clock-wise direction while removing to avoid stretching the ring.

Step 5 Remove Head

While holding the permeate port with your hand, simply pull the head from the shell. In some instances it may be required to thread a connection onto the permeate port and gently rock the head up and down to release the head from the shell.

HEAD REBUILDING

Prior to following this procedure, remove the head following the procedure listed.

Step 1 Remove Adapter

Pull the adapter from the permeate port by slowly pulling on the adapter body.

Step 2 Remove Permeate Port

Carefully remove the metal retaining ring from the permeate port as to not damage the ring or the port. A new retaining ring may be required to assemble the head. After the ring is removed, carefully slip the bearing plate off the permeate port and set it aside. Then simply pull the permeate port from the sealing plate.

Step 3 Inspect Feed Port

Push the port into the Bearing Plate to inspect the retaining ring and port for corrosion or damage. If none is found, the assembly should not be tampered with. If for any reason, the retaining ring is removed, please contact the factory as a new ring is required with special assembly instructions to ensure proper performance.

Step 4 Remove Seals

Remove the seal from the permeate port and set aside. Using a small tool, such as a screwdriver or a paper clip, remove the seal from the inside of the permeate port and set aside.

Step 5 Clean All Components

Using a mild soap solution, clean each component, rinse with fresh water and then dry with compressed air or a lint free towel.

Step 6 Inspect Components

Examine each component for corrosion or damage that may affect the performance of the vessel. Replace any components that have corrosion or visual damage. In addition, carefully inspect each seal for damage or wear. It is recommended to replace each seal at this time. Please be aware that seal condition may affect system performance.

Step 7 Lubricate Seals

Using extreme care, coat each seal with a thin layer of glycerin. Only a thin layer is required. Silicone lubricants can also be used; however, care should be taken to use as little as possible. Check with your membrane supplier before using these lubricants as they can foul membranes.

Step 8 Reassemble Head

Reversing the removal procedure, reassemble the head. Please note that a new permeate port retaining ring may be required to ensure correct component performance.

**1000 PSI
END PORT**

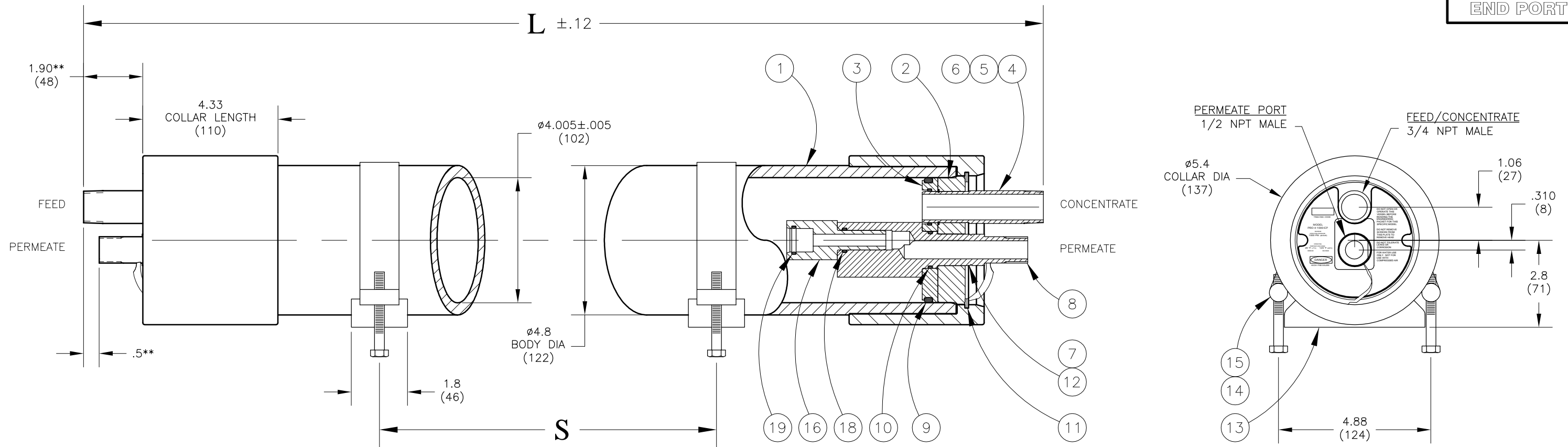

Shell Length Code	L		S Span in (mm)	Empty Weight lb (kg)
	3/4" NPT Feed inch (mm)	3/4" Grooved Feed inch (mm)		
-1	55 (1397)	59 (1499)	28 (711)	28 (13)
-2	95 (2413)	99 (2515)	51 (1295)	43 (20)
-3	135 (3429)	139 (3531)	73 (1854)	58 (26)
-4	175 (4445)	179 (4547)	95 (2413)	73 (33)
-5	215 (5461)	219 (5563)	117 (2972)	88 (40)
-6	255 (6477)	259 (6579)	140 (3556)	103 (47)

** 3/4" NPT feed port shown. Add 2" for 3/4" grooved feed port

ITEM	QTY	P/N	DESCRIPTION	MATERIAL
1	1	3040008	Shell	Filament Wound, Epoxy FRP
2	2	4040011	Bearing Plate	6061-T6 Aluminum, SB-221, Anodized
3	2	4040012-1	Sealing Plate	PVC Thermoplastic
4	2	4040014-1	Feed/Concentrate Port	SST Super Austenitic, 6% Mo, SB-675
5	2	6121100	Retaining Ring, F/C Port	Stainless Steel, 300 Series
6	2	6180120	Seal, F/C Port, O-Ring	Ethylene Propylene
7	2	4040019-1	Clocking Tab	Thermoplastic
8	2	4040063-1	Permeate Port	PVC Thermoplastic
9	2	6180342	Head Seal, O-Ring	Ethylene Propylene
10	2	6180120	Permeate Port Seal, O-Ring	Ethylene Propylene
11	2	4040047	Retaining Ring w/ Finger Pull	Stainless Steel, 300 Series
12	2	6121100	Retaining Ring, Permeate Port	Stainless Steel, 300 Series
13	2	4040037	Support Saddle	Polyurethane
14	2	4040040	Strap Assembly	Stainless Steel, 300 Series
15	4	6150001	Strap Screw	Stainless Steel, 300 Series
16	2	A/R	Adapter	PET Thermoplastic
17				
18	2	6180114	Adapter Seal, O-Ring	Ethylene Propylene
19	2	A/R	PWT Seal, O-Ring	Ethylene Propylene

NOTES:
DIMENSIONS IN INCHES (MM APPROX.)

FOR REFERENCE ONLY, NOT TO BE USED FOR CONSTRUCTION UNLESS CERTIFIED

CENTER VESSEL ON 2 SUPPORTS AT SPAN "S".

INCORRECT MANIFOLDING WILL CAUSE SEVERE LOCAL STRESS AROUND PORT AND MAY RESULT IN LEAKS AND PREMATURE FAILURE. TAKE EVERY PRECAUTION LISTED IN THIS PACKET.

INTERNAL PERMEATE PRESSURE MUST NOT EXCEED 125 PSI.

SPECIFICATIONS SUBJECT TO CHANGE WITHOUT NOTICE



ENGR	AP	5/22/03
QLTY	WJ	5/23/03
MRKT	DWE	5/22/03

PRO 4-1000-EP

ECO	REVISED	DRAWING	REV
03074	5/27/03	104006	F

ORDERING

Using the chart below, check the features you require and fax them with your purchase order to our customer service department.
Fax 760-597-4830; phone 760-599-4800.

LENGTH CODE

MODEL PRO 4-1000-EP -1 -2 -3 -4 -5 -6

EXTERIOR FINISH

- Standard** - white high-gloss polyurethane coating over a smooth surface
- Option** - other colors available for orders over 50 vessels. Call for pricing details.

CERTIFICATION

- Standard** - certified by Progressive Composite Technologies, not code stamped.
- Option** - ASME Code Section X, RP stamped certified by an ASME Authorized Inspector. Call for pricing details.
- Option** - ASME Code Section X, RP stamped per above and registered with the National Board. Call for pricing details.

HEAD SEAL

- Standard** - EPDM O-Ring

FEED/CONCENTRATE PORT CONFIGURATIONS

- Standard-** 3/4" IPS pipe thread (see Table on drawing for L dimension)
- Option-** 3/4" IPS grooved end (see Table on drawing for L dimension)

MEMBRANE INFORMATION

Brand _____ Model _____ This information is required at the time of order.

CUSTOM MATERIAL OPTIONS – Call for pricing details.

Only select from the options below when the standard listed materials per the drawing are not sufficient for your application.

SEAL PLATE

- PET Thermoplastic – for temperatures up to 176°F and high purity applications
- 316L Stainless Steel – for temperatures up to 176°F and high purity applications

PERMEATE PORT

Feed End – check one box

- PET (up to 176°F)
- 316L Stainless Steel

Opposite End – check one box

- PET (up to 176°F)
- 316L Stainless Steel

CUSTOM VESSEL OPTIONS – Call for pricing details.

- Option- High Temperature package** for continuous operation over 120°F
Includes each permeate port, seal plate and adapter in PET material.

Vessel configuration approved by _____

Date / /