



COMMERCIAL SERIES
REVERSE OSMOSIS DESALINATOR

INSTALLATION
&
OPERATION MANUAL

3000 E 2ND STREET
THE DALLES, OR 97058
USA

PHONE: 800-548-4502
541-296-4562
FAX: 541-296-3954
uswatermaker@gorge.net
www.uswatermaker.com

USWATERMAKER, INC.

**COMMERCIAL SERIES WATERMAKER
REVERSE OSMOSIS DESALINATOR**

INSTALLATION

&

OPERATION MANUAL

TABLE OF CONTENTS

<u>Section</u>	<u>Page No.</u>
1. SYSTEM SCHEMATICS	5
2. SYSTEM COMPONENTS & MAINTENANCE	10
3. INSTALLATION INSTRUCTIONS	14
4. FIRST TIME START-UP	16
5. GENERAL START-UP & SHUTDOWN PROCEDURES	18
6. MEMBRANE CLEANING & PRESERVATION	20
7. TROUBLE-SHOOTING GUIDE	23
8. MAJOR PARTS LIST	27
9. WARRANTY	28
10. COMPONENT LITERATURE	29

INTRODUCTION

USWATERMAKER, INC. watermakers are designed to provide the owner with the highest quality of potable water. This manual will inform the user of the safe operation and maintenance of the **USWATERMAKER, INC.** watermaker. The manual also lists the major components of the watermaker. Understanding the system's operation and component function is paramount for safety, effective use, and maintenance. Early problem detection and proper maintenance is the key to keeping a watermaker operating safely and efficiently. Thank you for selecting **USWATERMAKER, INC.** Please call 1-800-548-4502 or email us at uswatermaker@gorge.net if you have any questions.

SYSTEM SCHEMATICS

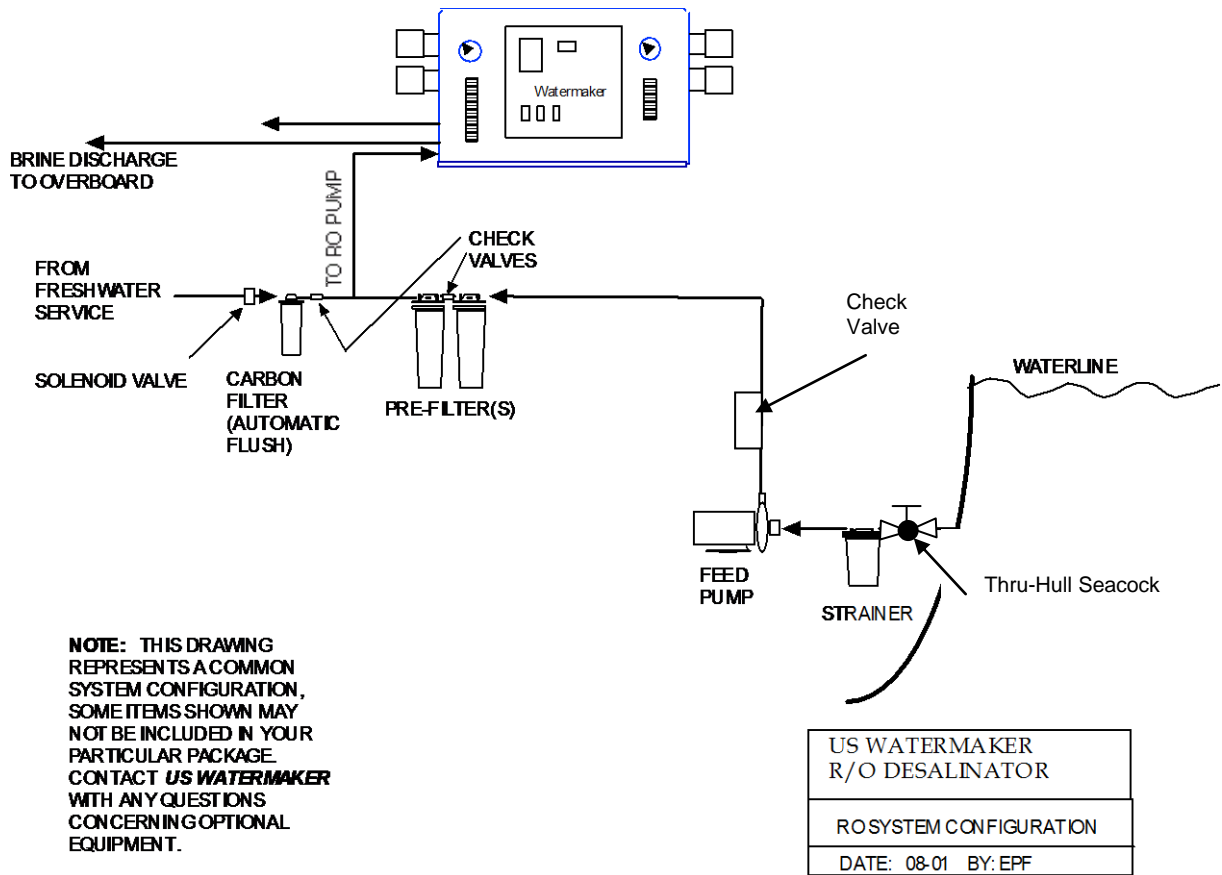

Figure 1

WATER FLOW DIAGRAM AND COMPONET LOCATION

Some components are optional

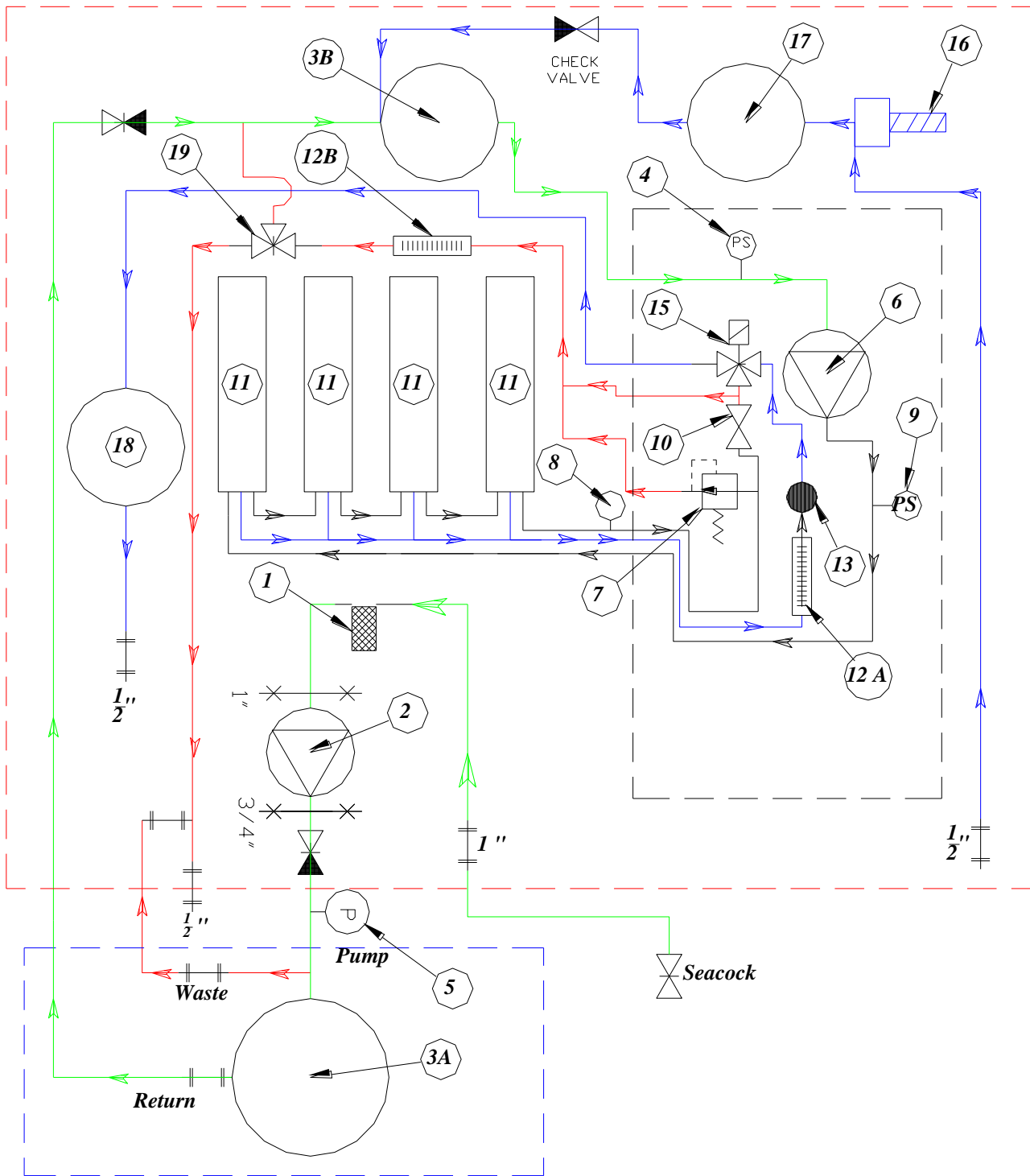

Figure 2

COMPONENT TABLE

No.	System components	No.	System components
1	Seawater Strainer	10	Pressure Control Valve
2	Feed Pump	11	Pressure Vessels
3A	Sand Filter	12A	Product Flow Meter
3B	Bag Filter	12B	Overboard Flow Meter
4	Low Pressure Switch	13	Salinity Sensor
5	Low pressure Gauge	15	Product Diverter Valve
6	High Pressure Pump	16	Automatic Fresh Water Flush
7	High Pressure Regulator	17	Carbon Filter
8	High Pressure Gauge	18	Mineral Filter
9	High Pressure Switch		

WATER CONNECTION DIAGRAM

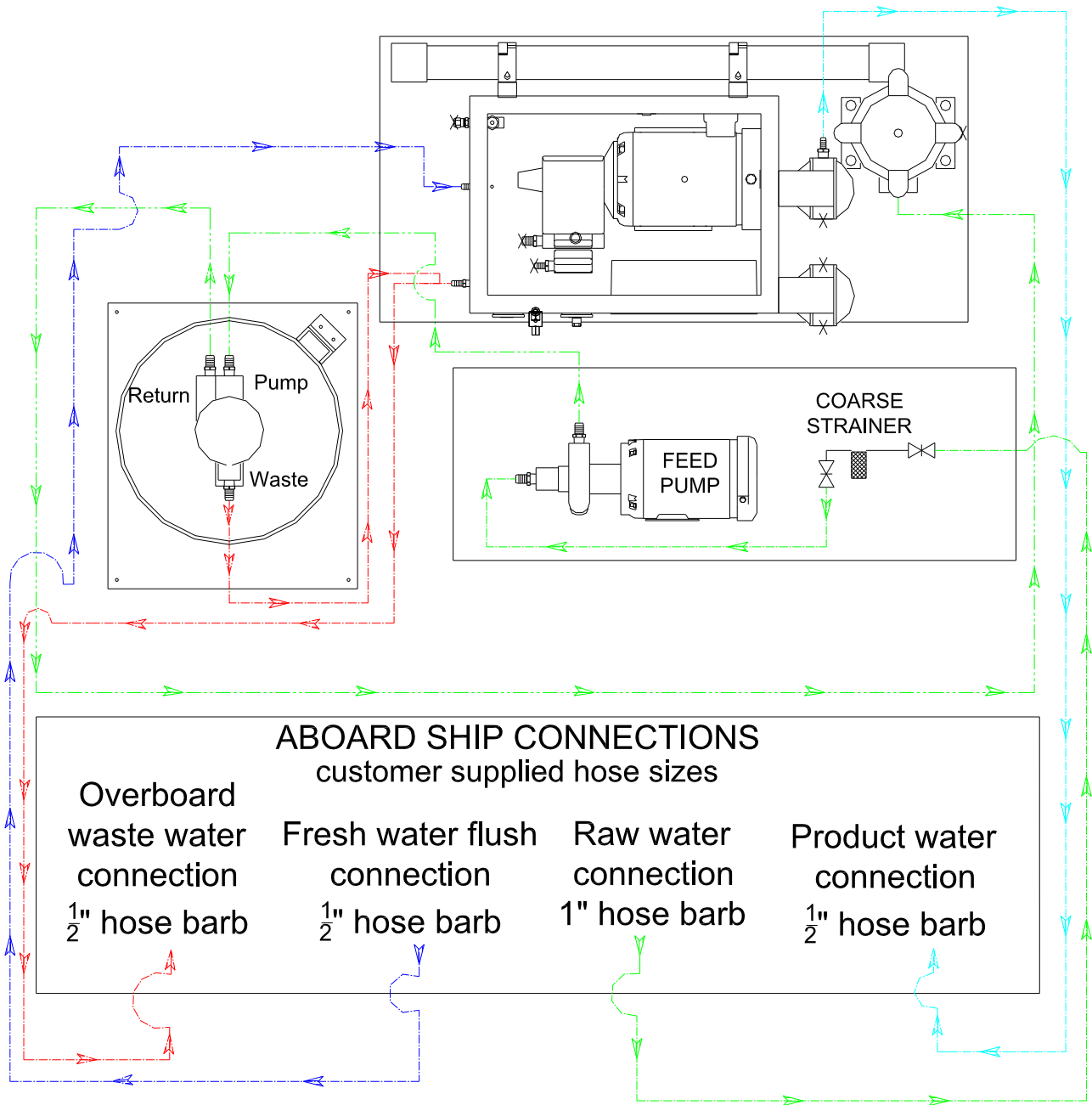

Figure 3

ELECTRICAL DIAGRAM

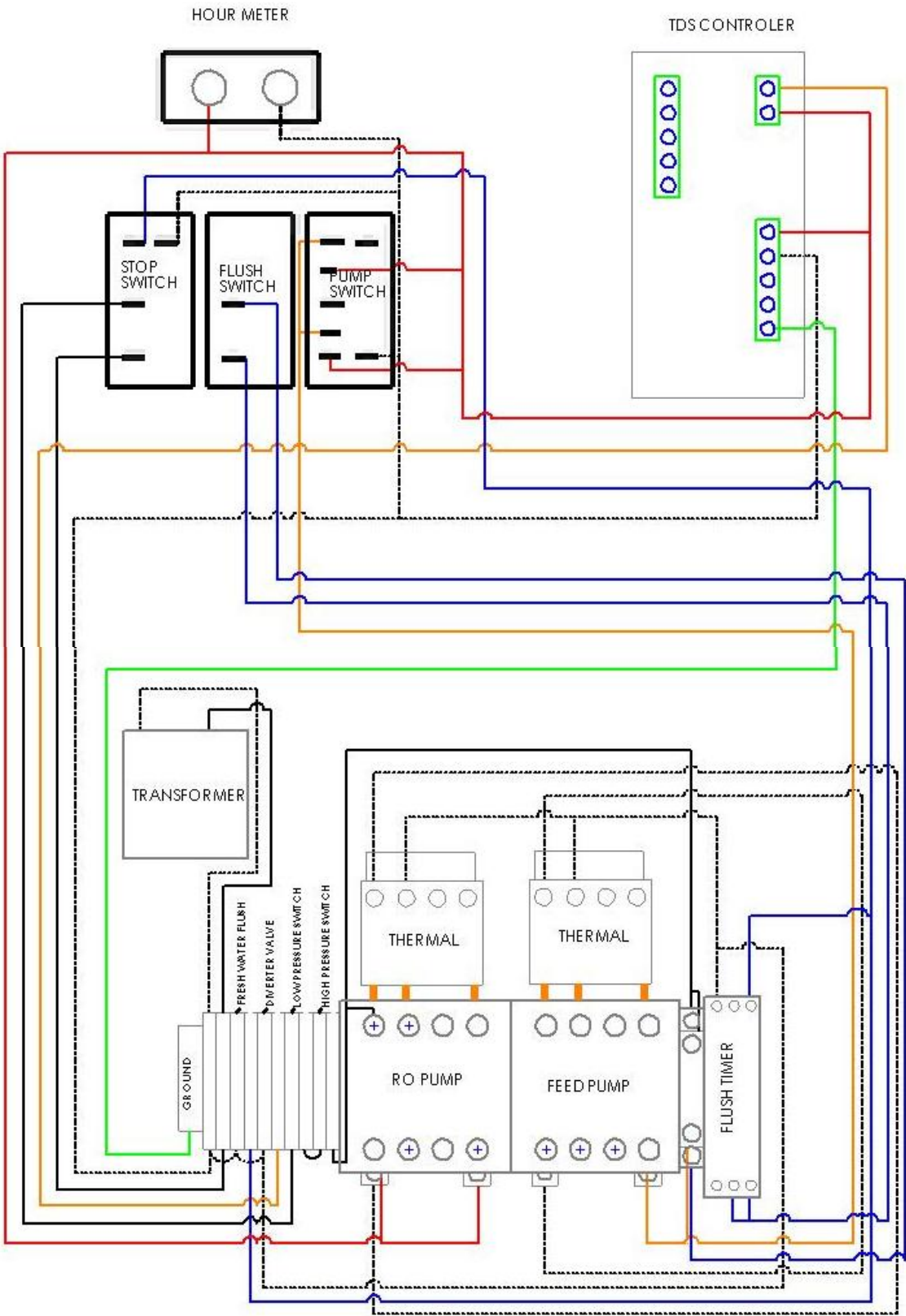

Figure 4

SYSTEM COMPONENTS

Listed below are the major components for the watermaker. Items are described consecutively from the raw water source to the product water output. Some components listed are options and do not necessarily come with all units.

1. SEA WATER STRAINER (supplied by installer)

A plain bronze housing with a coarse stainless steel screen used to remove foreign matter from the feed pump inlet ([Object 1, page 6](#)). The strainer protects the feed pump and prolongs pre-filter life.

MAINTENANCE: Clean screen every 30 days or sooner. Replace if screen is damaged or broken.

2. FEED PUMP

A feed pump ([Object 2, Page 6](#)) provides a positive pressure through the sand filter and pre-filter to the high-pressure pump. The full water flow at a positive pressure prevents cavitations in the high-pressure pump.

MAINTENANCE: check impeller for foreign material.

3. SAND FILTER & PRE-FILTER

The pre-filter ([Object 3, Page 6](#)) removes suspended solids of particulate matter from the feed water to protect the Reverse Osmosis Membrane. The filter element should be replaced if it becomes fouled or plugged with particulate matter. A fouled pre-filter is indicated by low feed pressure.

MAINTENANCE: Replace dirty filter elements approximately every 1 to 2 weeks or if the feed water pressure decreases noticeably. Media Filters may be back-flushed.

4. LOW PRESSURE SWITCH

A low-pressure switch ([Object 4, Page 6](#)) is located near the back of the low pressure gauge. The switch is wired to shut down the high-pressure pump motor if the feed pressure drops below 2 psig.

5. LOW PRESSURE (FEED WATER) GAUGE

The low pressure gauge ([Object 5, Page 6](#)) is located above the overboard flow meter on the front panel of the watermaker unit. The low pressure gauge indicates the feed water pressure between the pre-filter and high-pressure pump. A loss of feed pressure indicates pre-filter fouling or plugging. Erratic needle movement may indicate air introduced into the feed waterline. No pressure indicates the feed pump is not operating or has lost its prime.

6. HIGH PRESSURE PUMP

A positive displacement pump ([Object 6, Page 6](#)) is supplied to produce the flow to the Reverse Osmosis Membrane at the required pressure. This pump is a triplex ceramic plunger type designed for seawater. It has corrosion resistant materials for all wetted parts.

MAINTENANCE: Change oil after first 50 hours of operation. Check oil level during pre-filter changes. Periodic oil changes are required every three months or 500 hour intervals of operation.

7. HIGH PRESSURE REGULATOR

A high pressure regulator, located on the front panel below the pressure control valve, ([Object 7, Page 6](#)) builds pressure by restricting the flow of wastewater. The high pressure regulator is not in use when the pressure control valve ([Object 10, Page 6](#)) is in the start position. When the pressure-control valve is moved to the run position, the flow to the wastewater line is controlled by the high pressure regulator. The high pressure regulator protects the system from over pressure by increasing the flow as pressure rises. Adjust this valve to achieve desired product flow and pressure. Do not exceed 850 psi.

8. HIGH PRESSURE GAUGE

The high pressure gauge ([Object 8, Page 6](#)) is located above the pressure control valve on the front of the watermaker. The gauge shows the pressure inside the pressure vessel. The pressure should be maintained at 850 psig or below by setting the pressure-regulating valve ([Object 7, Page 6](#)).

9. R.O. MEMBRANE

The Reverse Osmosis Membrane (R.O. membrane) is located inside the pressure vessels ([Object 11, Page 6](#)). At high pressure, the water passes through the membrane to the exclusion of salt and other impurities. In this way it separates salt and raw water impurities from the product water.

MAINTENANCE: Consists of three procedures:

- a) Flush with non-chlorinated water for shutdown period of 3 weeks or less.
- b) Chemical cleaning and preserving for shutdown periods longer than 3 weeks.
- c) Chemical cleaning is required when the product flow is less than 10% of normal production.

NOTE: SEE WARRANTY INFORMATION REGARDING MEMBRANE CARE (Section 9)

10. PRESSURE CONTROL VALVE

The pressure control valve ([Object 10, Page 6](#)) is located on the watermaker's front panel, below the high pressure gauge. The pressure control valve has 2 positions: start and run. In the start position the pressure control valve is open to the wastewater line. Turning the valve's handle to the run position closes the valve to the wastewater line. If the high-pressure pump is running, closing the pressure control valve to the waste water line allows the high pressure regulator to build pressure.

11. PRESSURE VESSEL

The pressure vessel(s) contains the R.O. membrane(s) ([Object 11, Page 6](#)). Because the reverse osmosis process requires high pressure, caution is needed when working near or on the pressure vessels. Inspection of vessels is necessary to check for any damage that may cause failure of the vessels. Replace if any damage is indicated. Also visually inspect the end-plugs of the vessel(s), weekly for leaks.

12. FLOW METERS

The flow meters ([Object 12A & 12B, Page 6](#)) show the amount of product and brine moving through the system. The meters are read by the number across from the top of the float. The product flow meter is read in Gallons Per Hour (GPH). The overboard flow meter is read in Gallons Per Minute (GPM).

WARNING: DO NOT EXCEED STATED FLOW RATE FOR PRODUCT FLOW METER.

Size of Unit	Maximum Flow Rate
10,000 GPD	7 gallons per minute

13. SALINITY SENSOR

The salinity sensor probe ([Object 13, Page 6](#)) is installed down-stream from the product flow meter. The probe monitors the amount of salt in the water and sends a signal to the salinity controller, which displays that amount.

14. SALINITY MONITOR/CONTROLLER

The salinity controller is installed in the electrical main control panel. It receives an electrical signal from the salinity sensor. The signal is displayed as a measurement in parts per million (ppm) of Total Dissolved Solids (T.D.S.). This display is located on the main control panel's face. When the T.D.S. are over 500 ppm, the salinity controller diverts the product water overboard.

15. PRODUCT DIVERTER VALVE

The diverter valve ([Object 15, page 6](#)) is located inside the watermaker, bolted to the middle of the top support flange. It is placed down-stream from the salinity sensor probe. It is electrically controlled and diverts product water to or away from the product storage tank. The salinity controller controls the diverter valve's action.

NOTE: The operator may manually divert water overboard by depressing the "button" on side of the diverter valve and turning 1/4 turn to lock.

16. AUTOMATIC FRESHWATER FLUSH

The automatic freshwater flush ([Object 16, Page 6](#)) supplies the membranes with fresh water from the ship's pressurized potable water system. The automatic freshwater flush creates a cycle in which the pressure vessels are flooded with fresh water. The automatic freshwater flush cycle is activated every time the stop button is pressed. The pressure control valve ([Object 10, Page 6](#)) must be in the start position for the flush system to work properly.

17. CARBON FILTER

A carbon filter ([Object 17, Page 6](#)) is used to remove chlorine that may be present in the fresh water used to flush the system. Chlorine is harmful to the membranes. See carbon filter manufacturer's recommendations for changing and maintaining the carbon filter.

18. MINERAL FILTER

A mineral filter ([Object 18, Page 6](#)) is used to add minerals to the product water. Minerals are removed in the reverse osmosis process. Minerals can be added to the system to prevent the leaching of minerals from the storage tank and supply lines.

INSTALLATION INSTRUCTION

FOR TYPICAL SHIPBOARD INSTALLATION

1. REQUIRED OWNER SUPPLIED MATERIALS

NOTE: ALL FITTINGS AND PIPE MUST BE OF NON-FERROUS, NON-CORROSIVE TYPE.

a. BELOW WATER LINE

The customer must supply thru-hull fittings with a seacock valve. The seacock valve should be a 1/4 turn shut-off valve with a minimum 1.5" diameter orifice.

b. ABOVE WATER LINE

The customer must supply a thru-hull fitting for overboard brine/waste water. Fitting must have a minimum 1" diameter orifice.

c. CUSTOMER'S SHIPBOARD CONNECTIONS

The customer must supply the necessary hose and pipefitting. See figure below.

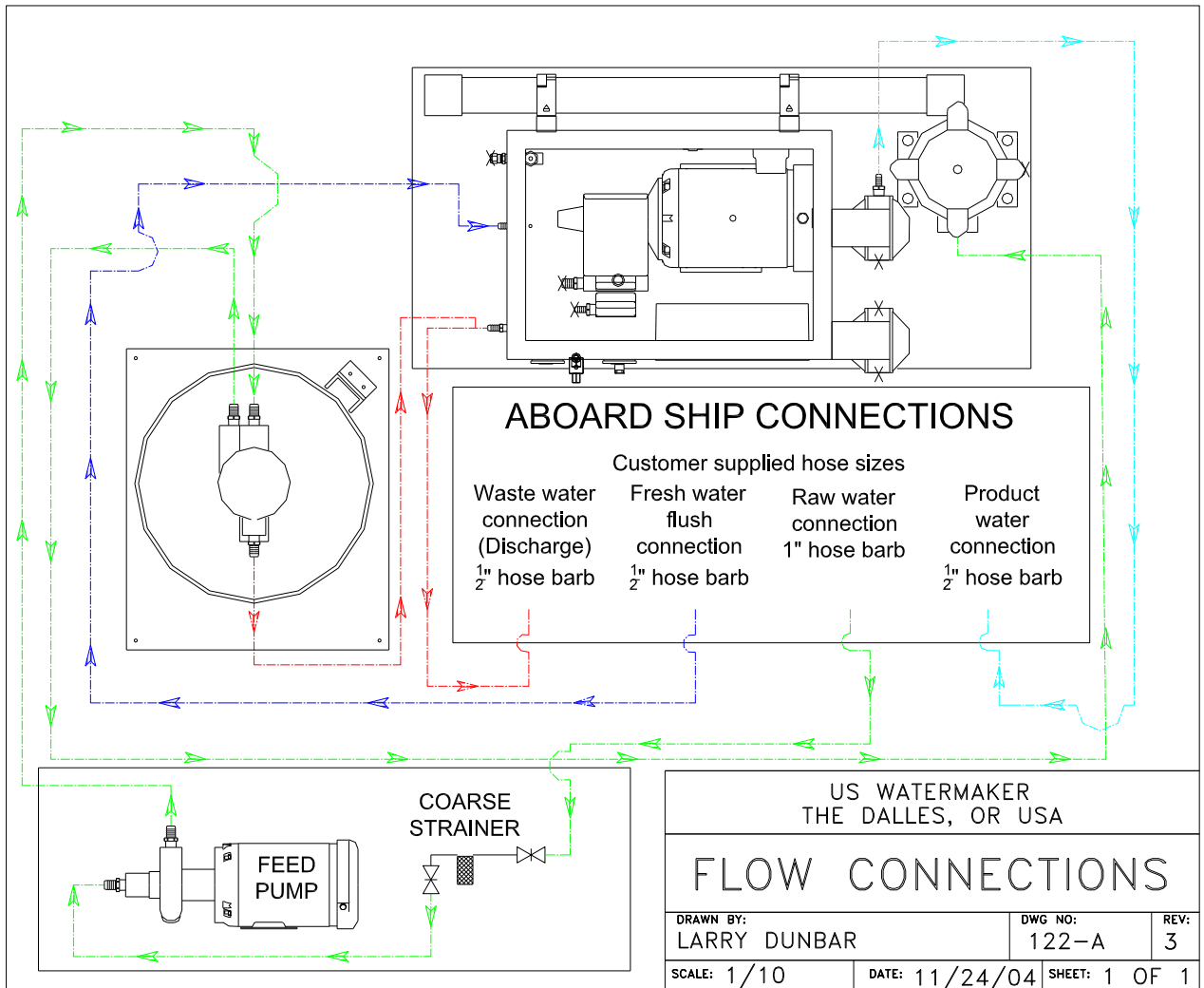

Figure 5

WARNING! DO NOT USE SHUT-OFF VALVES IN EITHER THE WASTE OR PRODUCT WATERLINES. IF WASTE OR PRODUCT LINES ARE CLOSED, DAMAGE TO THE WATERMAKER WILL OCCUR WHICH COULD RESULT IN INJURY!

NOTE: IF FERROUS METAL PIPING CANNOT BE AVOIDED, DIELECTRIC COUPLINGS SHOULD BE USED BETWEEN FERROUS AND NON-FERROUS MATERIALS.

2. COMPONENT LOCATION

The strainer, feed pump, and pre-filters should be located as close to the watermaker as possible. This prevents pressure drop associated with excessive piping. All components should be readily accessible for visual inspection and maintenance. Pre-filters must have space to remove housing and replace filter cartridges. These components should be located below the water line in shipboard installations.

3. POTABLE WATER STORAGE TANK

If the product water is to be run to potable water storage tank:

- a.** The tank must be non-pressurized type.
- b.** The line from the watermaker should enter into the top of the tank to allow least amount of backpressure for product water. Tank should be vented and be fitted with an overflow line.

SEE WARRANTY INFORMATION.

4. ELECTRICAL

Wire size for electrical power to the watermaker should meet the electrical code for the required current carrying capacity. The line voltage and the frequency must meet the system requirements. Refer to the control schematic for the electrical hook-up to the unit.

FIRST TIME START-UP PROCEDURE

This information provides start-up and R.O. system checkout. Failure to observe and follow these procedures could lead to serious injury and damage.

1. Check and make certain the electrical power to the watermaker is off at the source.
2. Check electrical power connections to the unit.
3. Check the three water line connections for proper flow paths, inlet and outlet directions for field installed components, and tightness of all connections.
4. Check the high-pressure pump for the proper amount of lubricating oil.
5. Move the handle of the pressure control valve to its fully open position. (The Start Position)
6. Turn on electrical power from the power source to the watermaker, but **do not** push the start button yet.
7. Open intake water seacock.
8. Hold the alarm reset button and press the feed pump start button. When the low pressure gauge reads a pressure of 5 to 8 psi, release the alarm reset button. If pressure is not reached within 30 seconds, stop the feed pump. Prime the intake waterline from the pre-filter back to the seacock. Restart the feed pump and continue start-up when intake water pressure is obtained.
9. Now that the feed pump is running, start the watermaker by pressing the start button. Observe the low pressure gauge and determine if pressure is remaining constant.

Operate the unit for a minimum of 10 minutes with the pressure control valve in the start position. The high-pressure gauge will read zero pressure. While operating in this condition, check for water leaks and correct as required, stopping the feed pump and/or watermaker if necessary.

10. Slowly, increase the pressure with the pressure control valve in increments of 100 PSI to a maximum of 850 PSI (**600 PSI for brackish water systems**). Check system with each step for leaks and proper operation. If leaks develop, stop the system and correct the problem. Restart the system at zero pressure. Slowly, increase system pressure to the next step.
11. Between 500 and 600 PSI (**200 - 300 PSI for brackish water systems**), product water should begin to flow into the flow meter. It may take a few minutes for the system to produce acceptable potable water. When the salinity (TDS) of the product water drops below the controller set point of 500PPM, the red LED light will turn off and the diverter valve will switch the product water from wastewater discharge to the storage tank line.

WARNING: DO NOT EXCEED STATED FLOW RATE FOR PRODUCT FLOW METER.

Size of Unit	Maximum Flow Rate
10,000 GPD	7 gallons per minute

When the watermaker is being run for the first time, discard the product water for the first 30 minutes of operation. This prevents any preservative chemical remaining in the R.O. membrane from getting into the product water storage system.

The salinity controller (TDS) set point has been pre-set at the factory. The controller will divert water to the holding tank when water quality is 500 PPM or less.

SHUTDOWN PROCEDURE

1. Lower the system pressure to zero by slowly turning the pressure control valve counter clockwise to the start position.
2. Shut down the watermaker by pressing the stop button.
3. The feed pump and high-pressure pump will both stop at the same time.
4. Close the inlet water seacock (if necessary).
5. Turn off the electrical power to the watermaker (if necessary).

GENERAL START-UP PROCEDURE

1. Check the high-pressure pump for the proper amount of lubricating oil.
2. Open the pressure control valve to its fully open position. (The Start Position)
3. Open intake water seacock.
4. Start the feed pump and observe the feed water gauge on the front of the watermaker. If 5 to 8 lbs. pressure is not reached within 30 seconds, stop the feed pump. Prime the intake waterline from the pre-filter back to the seacock. Restart the feed pump and continue start-up when intake water pressure is obtained.
5. Start the watermaker by depressing the start button. Observe the feed water pressure gauge and determine if feed pressure is remaining constant.
6. Operate unit for minimum 2 minutes at zero system pressure. Allow any trapped air to escape.
7. Slowly, increase the pressure with the pressure control valve in increments of 100 PSI to a maximum of 850 PSI (**600 PSI for brackish water systems**).
8. Product water should begin to flow between 500 and 600 PSI (**200 - 300 PSI for brackish water systems**), into the flow meter. It may take a few minutes for the system to produce acceptable potable water. When the salinity (TDS) of the product water drops below the controller set point of 500 PPM, the red LED light will turn off and the diverter valve will switch the product water from waste water discharge to the storage tank line.

WARNING: DO NOT EXCEED STATED FLOW RATE FOR PRODUCT FLOW METER.

Size of Unit	Maximum Flow Rate
10,000 GPD	7 gallons per minute

When the watermaker is first being run after preservative chemical has been used, discard the product water for the first 30 minutes of operation. This prevents any preservative chemical remaining in the R.O. membrane from getting into the product water storage system.

The salinity controller (TDS) set point has been pre-set at the factory. The controller will divert water to the holding tank when water quality is 500 PPM or less.

SHUTDOWN PROCEDURE

1. Lower the system pressure to zero by slowly turning the pressure control valve counter clockwise to the start position.
2. Shut down the watermaker by pressing the stop button.
3. The feed pump and high-pressure pump will both stop at the same time.
4. Close the inlet water seacock (if necessary).
5. Turn off the electrical power to the watermaker (if necessary).

MEMBRANE CLEANING & PRESERVATION

FLUSHING WITH NON-CHLORINATED FRESH WATER

The watermaker is equipped with an automatic Fresh Water Flush System. When the watermaker is shut down the auto-flush is activated for a period of 10 minutes. This allows fresh water to flow from your boat's potable water pressure system to flush the remaining seawater out of the watermaker and overboard. To flush the system again, simply press the stop button and the flush cycle will begin again. The pressure control valve must be in the start position for the Auto Flush System to work properly. When power to the watermaker is disconnected at the source, the Auto Flush System will not activate.

CHEMICAL CLEANING AND PRESERVING

CLEANING PROCEDURE

Shut the watermaker off and allow the Auto Flush System to complete its cycle.

Note: The water used to prepare these solutions must be free of chlorine or other oxidizing agents. Use a fresh water flush carbon filter to remove unwanted chlorine. Care must be taken to prevent these chemicals from entering the potable water system. Disconnect product water lines from the Watermaker during cleaning.

CLEANING SOLUTION 1:

This solution is used to remove acid soluble substances. It should be used before solution 2. Mix the powder (1 lb.) from container marked "Cleaning Solution 1" with 12 gallons of warm water. Circulate solution 1 at low pressure (less than 60 psi) through the membrane using the Watermaker pump for 60 minutes. Discard the solution. **(Follow all laws regarding discharge of cleaning solution overboard. If discharge is not allowed, the waste line can be run to a waste holding tank.)**

Flush the system with fresh water for 5 minutes.

CAUTION: Cleaning Solution 1 contains Citric Acid. Avoid contact with skin and eyes

DO NOT TAKE INTERNALLY. Keep away from food. IF SWALLOWED: Give tap water or milk of magnesia: GET MEDICAL ATTENTION.

IN CASE OF SKIN OR EYE CONTACT: Immediately flush with plenty water for at least 15 minutes. GET MEDICAL ATTENTION.

KEEP AWAY FROM CHILDREN.

CLEANING SOLUTION 2:

This solution is used to remove microbiological slime and other organic buildup. It should be used after solution 1. Mix the powder (1 lb.) from container marked "Cleaning Solution 2" with 12 gallons of warm water. Circulate solution 2 at low pressure (less than 60 psi) through the membrane using the Watermaker pump for 60 minutes. Discard the solution. **(Follow all laws regarding discharge of cleaning solution overboard. If discharge is not allowed, the waste line can be run to a waste holding tank.)**

Flush the system with fresh water for 5 minutes.

CAUTION: Cleaning Solution 2 contains Tri-sodium Phosphate. Avoid contact with skin or eyes.

DO NOT TAKE INTERNALLY. Keep away from food. IF SWALLOWED: give plenty of tap water. GET MEDICAL ATTENTION.

IN CASE OF SKIN OR EYE CONTACT: Immediately flush with plenty of water for at least 15 minutes. GET MEDICAL ATTENTION.

KEEP AWAY FROM CHILDREN.

PRESERVATION OF MEMBRANE

NOTE: Protectant does not need to be installed to preserve the membranes if the watermaker is shutdown for less than three weeks.

This solution is used to protect the membrane from microbiological growth and damage during periods of extended storage. It should be used after solutions 1 and 2. Mix the powder (1 lb.) from container marked "Membrane Protectant" with 12 gallons of warm water. Circulate Protectant solution at low pressure (less than 60 psi) through the membrane using the Watermaker pump. When the entire volume of the membrane is completely full of Protectant solution, stop the pump and plug the feed and waste lines to prevent air from entering the system.

When restarting the system after storage, flush the system with seawater using the feed pump for 15 minutes and discard the solution. **(Follow all laws regarding discharge of cleaning solution overboard. If discharge is not allowed, the waste line can be run to a waste holding tank.)** Then start the Watermaker. Let the Watermaker run for 15 minutes. Check the product water with a salinity meter (reading must be less than 500 ppm) before allowing product water to flow to your fresh water storage tank.

CAUTION: Membrane Protectant contains Sodium Metabisulfite. Avoid contact with skin and eyes.

DO NOT TAKE INTERNALLY. Keep away from food. IF SWALLOWED: Give plenty of tap water. GET MEDICAL ATTENTION.

IN CASE OF SKIN OR EYE CONTACT: Immediately flush with plenty of water for at least 15 minutes. **GET MEDICAL ATTENTION.**

KEEP AWAY FROM CHILDREN.

COMMERCIAL SERIES WATERMAKER TROUBLE-SHOOTING GUIDE

<u>ABNORMAL CONDITION</u>	<u>POSSIBLE CAUSE</u>	<u>REPAIR PROCEDURE</u>
Feed Water Low Pressure	Feed water inlet valve plugged or closed	Clear debris. Open valve
	Sea strainer plugged	Remove and clean the mesh screen
	Loss of prime on the feed water pump system	Check for air. Reprime if needed
	Low pressure pump not running	Check power
	Pre-filter clogged	Replace element or pre-filter bag
Low system pressure from high pressure pump	Worn high pressure seals	Replace seals
	Water leak from below the high pressure pump	Replace low pressure seals
	R.O. pressure vessel leaks from end plug	Replace O-Ring seal
Automatic shut-down	Low feed water pressure/flow	See feed water low pressure
No product water	Worn parts within the Membrane	Replace membrane
	Air leaks before high pressure pump inlet	Locate source and correct
Low product water flow	Under pressurization	Increase the system pressure to bring the flow up to specified level. No higher than 850 psig
	Sea water temperature has decreased	Adjust the system pressure to achieve specified flow. No higher than 850 psig

<u>ABNORMAL CONDITION</u>	<u>POSSIBLE CAUSE</u>	<u>REPAIR PROCEDURE</u>
Low product water flow (continued)	Inaccurate or inoperative product water flow meter	Replace with new flow meter
	Sea strainer or pre-filter is clogged	Clean filters
	Dirty, fouled or worn pump inlet or discharge valves	Clean or replace valve
	Feed water salinity is excessively high	Adjust the system pressure control to achieve specified flow
High product water flow	Over pressurization	Decrease the system pressure
	Decrease in feed water salinity	Same as above
	Sea water temperature has increased	Same as above
	Worn product port O-ring at the end of the plug	Remove the end plug and replace O-Ring
	Hole in the membrane	Replace the membrane
High pressure pump runs roughly and product water flow is low	Air entering suction line	Check for air leaks and check for clogged inlet
	Worn or stuck discharge valves in pump	Replace valves
Product water flow fluctuates and/or declines gradually	Break down of water seals	Replace seals
	Dirty valve, worn valve or valve seal	Clean or replace valves and seals
	Dirt in pressure regulating valve	Clean Valve
	Sea strainer and/or pre-filter clogged	Clean or replace filters

ABNORMAL CONDITION**POSSIBLE CAUSE****REPAIR PROCEDURE**

Oil leaking in the area of the high pressure pump

Worn plunger seals, or loose crankcase rear cover

Replace seals. Tighten cover screw, and/or worn shaft seal screws. If oil sight gauge is damaged, replace sight gauge, replace seal and refill crankcase to proper oil level

Loose oil drain plug

Tighten drain plug and refill crankcase to proper oil level

Oil appears milky color in sight gauge, but level does not rise

Condensation in oil gauge

Change oil more frequently. Remove sight gauge drain, clean and reinstall

Oil turns milky color in sight gauge, and level rises

Plunger seals leak

Replace seals

Loud knock in the high pressure pump

Damaged connecting rod knocking on the crankshaft. Could be caused by lack of lubrication including water in the oil

Replace high pressure pump

When system is started motor hums, motor does not turn

Motor starting capacitor

Replace the starting capacitor

Start button is depressed but system does not start

Power source is off

Reset circuit breaker

Switch is faulty

Replace switch

Power source is not proper voltage for system

Install proper power configuration source

Defective low pressure switch or low feed water pressure

Find source of low pressure and/or replace low pressure switch

Loose electrical connections

Check all electrical connections.
NOTE: Be cautious of electrical shock, do all such work with the system disconnected from the power source.

ABNORMAL CONDITION**POSSIBLE CAUSE****REPAIR PROCEDURE**

System starts when the start switch is depressed but stops when released

Loose or corroded electrical connections

Same as above.

Diverter valve will not switch product water outlet port to waste water dump salinity when is above set point

Burned out coil

Replace coil

Salinity controller is out of calibration

Recalibrate controller

Diverter valve manual override is depressed

Release the button

Salinity cell is corroded or contaminated

Replace or clean salinity cell

MAJOR PARTS LIST

COMMERCIAL SERIES WATERMAKER

<u>Part Description</u>	<u>Part Number</u>
Sand Filter	Hayward S-180T
Pre-filter Housing	X-100 Pre-filter Housing
Bag Filters	X-100-5 & X-100-25
Low Pressure Switch	SM-P1C
High Pressure Switch	96201-BB2-T2
Low Pressure Gauge	CBM-30-0-60
High Pressure Gauge	CBM-1000
Feed Pump	March TE-7R-MD
High Pressure Pump	CAT PUMPS® 2531 SS
Three Phase Motor 60 Cycle	Baldor M2333T
High Pressure Hose	HP ¾"
Pressure Vessel Assembly with End Plugs	Pro 8-1000-EP
Membrane	SWC5-8040
Pressure Regulator	CAT PUMPS® 7021.100
Pulsation Dampener	6014 SS
Pressure Control Ball Valve	SS-44F6
Product Flow Meter	75202106C06
Overboard Flow Meter	72050106C06
Salinity Monitor	BL-1983329-1
Contacto – Feed Pump	C09
Contacto – High Pressure Pump	CU40
Thermal Overload, Feed Pump	130292
Thermal Overload, High Pressure Pump	RHN-80A2
Start Switch	V85BU11B-A2CAM-100
Stop Switch	V35AA10B-AMCAN-100
Hour Meter	HOBBS110
Diverter Valve	0131F ½
Flush Timer	MUR1
Flush Solenoid	656-2408
UV Sterilizer	SL-1

USWATERMAKER, INC. WATERMAKER LIMITED WARRANTY

USWATERMAKER, INC. watermakers are warranted to be free from defects in workmanship and material for one year from date of manufacturer's shipment. This warranty is limited to repairing or replacing the product or component which manufacturer's investigation shows were defective at time of shipment by the manufacturer. All products and components subject to this warranty shall be returned F.O.B. **USWATERMAKER, INC.**, 3000 E 2nd Street, The Dalles, OR 97058, for examination repair and/or replacement.

THE EXPRESS WARRANTY SET FORTH IS IN LIEU OF ALL OTHER WARRANTIES, EXPRESS OR IMPLIED, INCLUDING WITHOUT LIMITATION ANY WARRANTIES OF MERCHANTABILITY OR FITNESS FOR A PARTICULAR PURPOSE, AND ALL SUCH WARRANTIES ARE HEREBY DISCLAIMED AND EXCLUDED BY THE MANUFACTURER. Repair or replacement of the defective product or component as provided above is the sole and exclusive remedy provided hereunder. The manufacturer shall not be liable for any loss, cost, damages, or expenses, including, but not limited to economic, incidental or consequential damages, directly or indirectly arising from or related to the sale or use of this product.

This warranty is subject to the following warranty conditions concerning R.O. membranes:

1. At no time shall the feed water to the membrane contain oil, grease, or other organic or inorganic matter harmful to the membrane.
2. The feed water temperature shall not exceed 113 degrees F. (45 C).
3. Feed water shall contain no colloidal sulfur.
4. Membranes shall not be exposed to pressure greater than 1000 psi for Seawater or 600 psi for Brackish Water.
5. Backpressure (where permeate/product static pressure exceeds reject static pressure) shall not exceed 5 psi at any time.
6. The membrane(s) shall be operationally protected against shock loading (water hammer).
7. During continuous operation the pH shall be no less than 2.0 nor greater than 11.0 pH. Adjust if required, with H₂SO₄ or approved equivalent.
8. Recovery ratio shall be consistent with concentration of sparingly soluble salts.
9. There shall be no membrane scaling caused by failure of the chemical dosing system (e.g., Ca, Ba or Sr salts).
10. There shall be no membrane fouling by colloidal or precipitated solids.
11. The feed water shall contain no ozone, permanganate or other strong oxidizing agents.
12. Adequate provisions against microbiological contamination shall be incorporated into the system design, as well as into operating and maintenance procedures.
13. Cleaning shall be initiated at 10% to 15% normalized product flow decline.
14. The membrane(s) shall not be exposed during cleaning, or in shutdown periods, to a pH less than 1 or greater than 12.
15. Any chemical agent, whether cleaner, Protectant or otherwise, must be approved by **USWATERMAKER, INC.** prior to use.